SECOND

QUARTER

2000

*semiconductor
product guide*

SONY

Table of Contents

CCDs

Area Sensor — Color	2
Area Sensor— Black & White	3
Area Sensor — Progressive Scan	4
Linear Sensor	4
Block Diagrams	5-6

CAVD Multimedia Products	7
---------------------------------------	----------

Laser Diode	8
--------------------------	----------

LCD (Data Projector)	9
-----------------------------------	----------

Mixed Signal Systems	10-11
-----------------------------------	--------------

Memory	12
---------------------	-----------

Serial/Optical Communications	13-15
--	--------------

TV	16
-----------------	-----------

Wireless Communications	17-22
--------------------------------------	--------------

Device Number Index	23
----------------------------------	-----------

Sales Offices	24-25
----------------------------	--------------

CCD Area Sensor — Color

CCD Image Sensor	System	NTSC	ICX038DNA/DNB	ICX054BK ⁽¹⁾	ICX058CK ⁽¹⁾	ICX206AK ⁽¹⁾ /AKB ⁽¹⁾
		PAL	ICX039DNA/DNB	ICX055BK ⁽¹⁾	ICX059CK ⁽¹⁾	ICX207AK ⁽¹⁾ /AKB ⁽¹⁾
	Optical Size (inch)		1/2	1/3	1/3	1/4
	Effective Pixels (H x V)	NTSC	768 x 494	510 x 492	768 x 494	510 x 492
		PAL	752 x 582	500 x 582	752 x 582	500 x 582
Unit Cell Size (H x V)	NTSC	8.4µm x 9.8µm	9.6µm x 7.5µm	6.35µm x 7.4µm	7.15µm x 5.55µm	
	PAL	8.6µm x 8.3µm	9.8µm x 6.3µm	6.5µm x 6.25µm	7.3µm x 4.7µm	
Timing Driver	Vertical Driver		CXD1267AN	CXD1267AN	CXD1267AN	CXD1267AN
	Horizontal Driver		Built into T.G.	Built into T.G.	Built into T.G.	Built into T.G.
	Timing Generator		CXD1265R	CXD2401R	CXD1265R	CXD2401R
	Sync Signal Generator		CXD1217M	CXD1217M	CXD1217M	CXD1217M
Signal Processing	Sample and Hold/AGC		CXA1390AR	CXA1390AR	CXA1390AR	CXA1390AR
	Matrix, Process		CXA1391R	CXA1391R	CXA1391R	CXA1391R
	Encoder		CXA1592R	CXA1592R	CXA1592R	CXA1592R
	CCD Delay Line for Chroma		CXL1517M	CXL1518M	CXL1517M	CXL1518M
	CCD Delay Line for Y		CXL5504M	CXL5504M	CXL5504M	CXL5504M

CCD Image Sensor	System	NTSC	ICX208AK ⁽¹⁾ /AKB ⁽¹⁾	ICX076AK ⁽²⁾	ICX096AKE ⁽¹⁾
		PAL	ICX209AK ⁽¹⁾ /AKB ⁽¹⁾	ICX077AK ⁽²⁾	ICX097AKE ⁽¹⁾
	Optical Size (inch)		1/4	1/5	1/6
	Effective Pixels (H x V)	NTSC	768 x 494	362 x 492	510 x 492
		PAL	752 x 582	358 x 583	500 x 582
Unit Cell Size (H x V)	NTSC	4.75µm x 5.55µm	8.1µm x 4.45µm	4.8µm x 3.75µm	
	PAL	4.85µm x 4.65µm	8.2µm x 3.75µm	4.9µm x 3.15µm	
Timing Driver	Vertical Driver		CXD1267AN	CXD1267AN	CXD1267AN
	Horizontal Driver		Built into T.G.	Built into T.G.	Built into T.G.
	Timing Generator		CXD1265R	N/A	CXD2401R
	Sync Signal Generator		CXD1217M	N/A	CXD1217M
Signal Processing	Sample and Hold/AGC		CXA1390AR	N/A	CXA1390AR
	Matrix, Process		CXA1391R	N/A	CXA1391R
	Encoder		CXA1592R	N/A	CXA1592R
	CCD Delay Line for Chroma		CXL1517M	N/A	CXL1518M
	CCD Delay Line for Y		CXL5504M	N/A	CXL5504M

NOTES:

1. Super HAD CCD™ — Super HAD CCD is a trademark of Sony Corporation. The Super HAD CCD is a version of Sony's high performance CCD HAD (Hole Accumulation Diode) sensor with sharply improved sensitivity by the incorporation of a new semiconductor technology developed by Sony Corporation.
2. No system IC for ICX076AK/ICX077AK.

CCD Area Sensor — Black & White

CCD Image Sensor	System	EIA	ICX082AL	ICX038DLA	ICX054BL ⁽¹⁾	ICX058CL ⁽¹⁾
		CCIR	ICX083AL	ICX039DLA	ICX055BL ⁽¹⁾	ICX059CL ⁽¹⁾
	Optical Size (inch)		2/3	1/2	1/3	1/3
	Effective Pixels (H x V)	EIA	768 x 494	768 x 494	510 x 492	768 x 494
		CCIR	752 x 582	752 x 582	500 x 582	752 x 582
Unit Cell Size (H x V)	EIA	11.6µm x 13.5µm	8.4µm x 9.8µm	9.6µm x 7.5µm	6.35µm x 7.4µm	
	CCIR	11.6µm x 11.2µm	8.6µm x 8.3µm	9.8µm x 6.3µm	6.5µm x 6.25µm	
Timing Driver	Vertical Driver		CXD1268M	CXD2463R	CXD2463R	CXD2463R
	Horizontal Driver		74HC04	CXD2463R	CXD2463R	CXD2463R
	Timing Generator		CXD1261AR	CXD2463R	CXD2463R	CXD2463R
	Sync Signal Generator		Built into T.G.	CXD2463R	CXD2463R	CXD2463R
Signal Processing	Sample and Hold AGC		CXA1310AQ	CXA1310AQ	CXA1310AQ	CXA1310AQ
	AGC		CXA1310AQ	CXA1310AQ	CXA1310AQ	CXA1310AQ
	Matrix, Process		CXA1310AQ	CXA1310AQ	CXA1310AQ	CXA1310AQ
	Encoder		CXA1310AQ	CXA1310AQ	CXA1310AQ	CXA1310AQ

CCD Image Sensor	System	EIA	ICX206AL ⁽¹⁾	ICX208AL ⁽¹⁾	ICX076AL
		CCIR	ICX207AL ⁽¹⁾	ICX209AL ⁽¹⁾	ICX077AL
	Optical Size (inch)		1/4	1/4	1/5
	Effective Pixels (H x V)	EIA	510 x 492	768 x 494	362 x 492
		CCIR	500 x 582	752 x 582	358 x 583
Unit Cell Size (H x V)	EIA	7.15µm x 5.55µm	4.75µm x 5.55µm	8.1µm x 4.45µm	
	CCIR	7.3µm x 4.7µm	4.85µm x 4.65µm	8.2µm x 3.75µm	
Timing Driver	Vertical Driver		CXD2463R	CXD2463R	CXD1267AN
	Horizontal Driver		CXD2463R	CXD2463R	Built into T.G.
	Timing Generator		CXD2463R	CXD2463R	CXD2409R
	Sync Signal Generator		CXD2463R	CXD2463R	Built into T.G.
Signal Processing	Sample and Hold AGC		CXA1310AQ	CXA1310AQ	CXA1310AQ
	AGC		CXA1310AQ	CXA1310AQ	CXA1310AQ
	Matrix, Process		CXA1310AQ	CXA1310AQ	CXA1310AQ
	Encoder		CXA1310AQ	CXA1310AQ	CXA1310AQ

NOTE:

1. Super HAD CCD™ — Super HAD CCD is a trademark of Sony Corporation. The Super HAD CCD is a version of Sony's high performance CCD HAD (Hole Accumulation Diode) sensor with sharply improved sensitivity by the incorporation of a new semiconductor technology developed by Sony Corporation.

CCD Area Sensor — Progressive Scan

Classification		AK: Color		AL: Black/White	
CCD Image Sensor	System	ICX085AK ⁽¹⁾ /AL	ICX074AK ⁽¹⁾ /AL	ICX084AK ⁽¹⁾ /AL	ICX098AK ⁽¹⁾
		—	ICX075AK ⁽¹⁾ /AL	—	—
	Optical Size (inch)	2/3	1/2	1/3	1/4
	Effective Pixels (H x V)	1300 x 1030	659 x 494	659 x 494	659 x 494
		—	782 x 582	—	—
	Unit Cell Size (H x V)	6.7μm x 6.7μm	9.9μm x 9.9μm	7.4μm x 7.4μm	5.6μm x 5.6μm
	—	8.3μm x 8.3μm	—	—	
Timing Driver	Vertical Driver	CXD1268M x 2	CXD1268M	CXD1267AN	Built into T.G.
	Horizontal Driver	74AC04	74HC04	—	Built into T.G.
	Combination Driver	—	CXD1250M	—	Built into T.G.
	Timing Gen. & Sync Gen.	CXD2437TQ	CXD2408AR(074) CXD2424R(075)	CXD2434ATQ	CXD2450R
Signal Process	CDS & AGC	CXA2006Q	CXA1690Q x 2	CXA2006Q	CXA2006Q
	A/D Converter	CXD2311AR	CXD2311AR	CXD2311AR	CXD2311AR

Classification		AK: Color	AL: Black/White
CCD Image Sensor	System	ICX204AK ⁽¹⁾ / AL ⁽¹⁾	ICX205AK ⁽¹⁾ / AL ⁽¹⁾
		—	—
	Optical Size (inch)	1/3	1/2
	Effective Pixels (H x V)	1034 x 779	1392 x 1040
		—	—
Unit Cell Size (H x V)	4.65μm x 4.65μm	4.65μm x 4.65μm	
	—	—	
Timing Driver	Vertical Driver	Built into T.G.	Built into T.G.
	Horizontal Driver	Built into T.G.	Built into T.G.
	Combination Driver	Built into T.G.	Built into T.G.
	Timing Gen. & Sync Gen.	CXD2457R	CXD2460R
Signal Process	CDS & AGC	CXA2006Q	CXA2006Q
	A/D Converter	CXD2311AR	CXD2311AR

NOTE:

1. WfineCCD™ — Wfine CCD is a trademark of Sony Corporation. It represents a CCD adopting progressive scan, primary color filter, and square pixel.

CCD Linear Image Sensor

	Product Name	Effective Pixels	Pixel Size (μm)	Sensitivity (V/[lx • s])	Max. Data (MHz)	Resolution (DPI)	Package	Pins
Color (RGB)	ILX548K ⁽¹⁾	5340 x 3	4 x 4	R 2.5	5 x 3	A4 600	CERDIP	22
	ILX550K ⁽¹⁾	10680 x 3	(4μm pitch)	G 2.9 B 2.6	(R,G,B)	A4 1200	SDIP	24
B/W	ILX551A ⁽¹⁾	2048	14 x 14	40	10	B4 200	Ceramic	22
	ILX553A ⁽¹⁾	5150	7 x 7	13	16	A4 600	Plastic	22
	ILX554A ⁽¹⁾	2048	14 x 56	260	2	—	CERDIP	22
	ILX751A ^(1,2)	2048	14 x 14	40	10	B4 200	Ceramic	22

NOTES:

1. Under development.
2. Provided with shutter function.

CCD Color Camera Block Diagram for 1/2", 1/3", 1/4", 1/6" Optical Size

CCD Color Image Sensor

ICX038DNA / ICX039DNA (768H), 1/2"
 ICX038DNB / ICX039DNB (768H), 1/2"
 ICX054BK / ICX055BK (510H), 1/3"

ICX058CK / ICX059CK (768H), 1/3"
 ICX206AK / ICX207AK (510H), 1/4"
 ICX208AK / ICX209AK (768H), 1/4"

ICX206AKB / ICX207AKB (510H), 1/4"
 ICX208AKB / ICX209AKB (768H), 1/4"
 ICX096AKE / ICX097AKE (510H), 1/6"

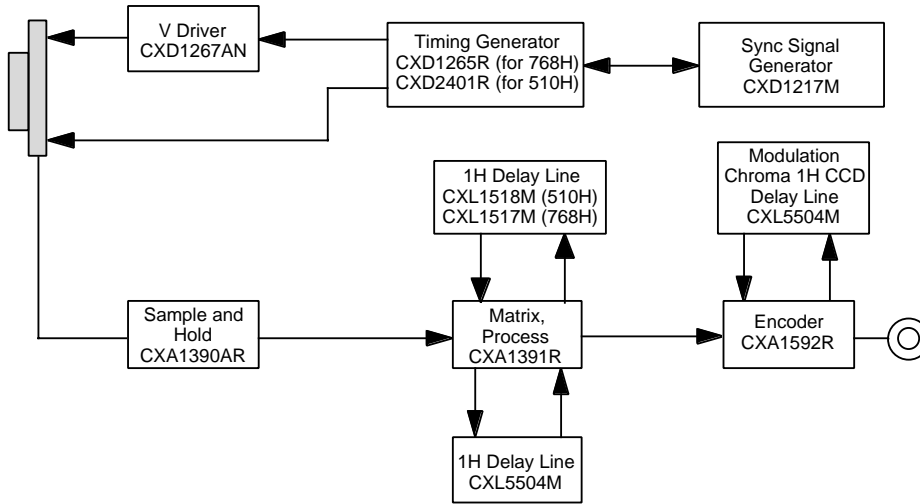

CCD Black/White Camera Block Diagram for 2/3", 1/5" Optical Size

CCD B/W Image Sensor

ICX082AL / ICX083AL (768H), 2/3"

ICX076AL / ICX077AL (362H), 1/5"

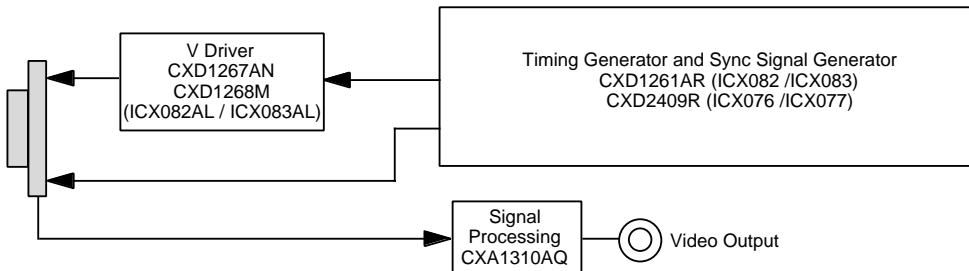

CCD Black/White Camera Block Diagram for 1/2", 1/3", 1/4" Optical Size

CCD B/W Image Sensor

ICX038DLA / ICX039DLA (768H), 1/2"

ICX054BL / ICX055BL (510H), 1/3"
 ICX058CL / ICX059CL (768H), 1/3"

ICX208AL / ICX209AL (768H), 1/4"
 ICX206AL / ICX207AL (510H), 1/4"

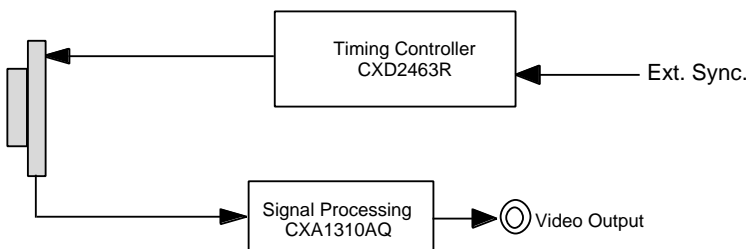

Progressive Scan CCD System Block Diagram for 1/2" Optical Size

ICX074AL / ICX075AL, B/W

ICX074AK / ICX075AK, Color

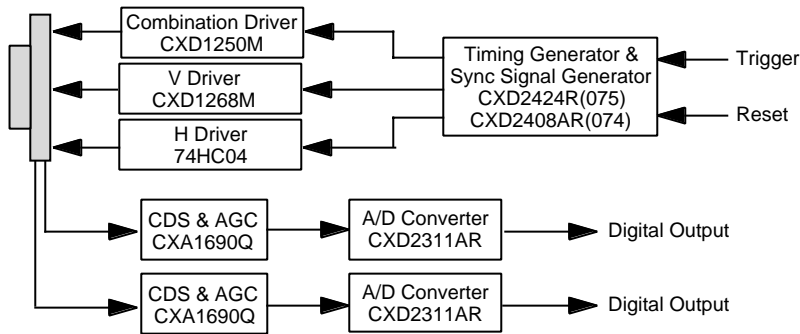

Progressive Scan CCD System Block Diagram for 1/3" and 1/4" Optical Size

ICX084AL, B/W

ICX084AK, Color

ICX098AK, Color

ICX204AK, Color
ICX204AL, B/W

ICX205AK, Color
ICX205AL, B/W

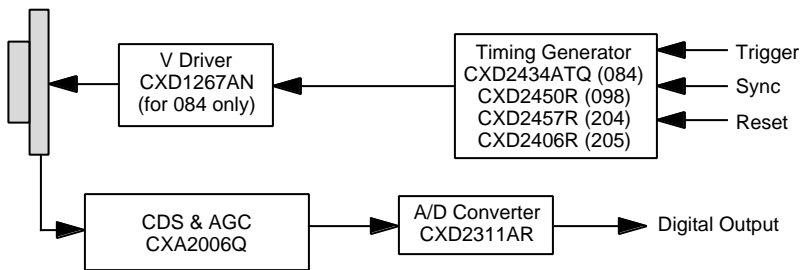

Progressive Scan CCD System Block Diagram for 2/3" Optical Size

ICX085AL, B/W

ICX085AK, Color

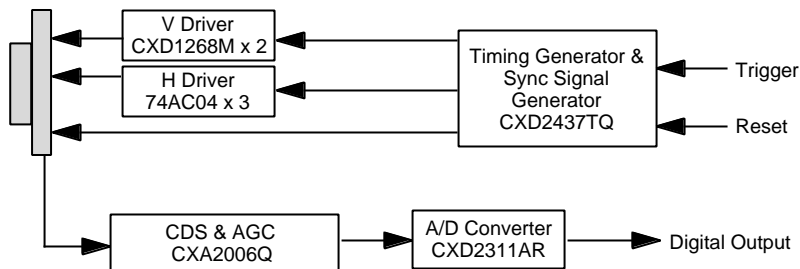

CAVD Multimedia Products

Video Processing

- MPEG Video Decoder

Part Number	Applications	Features	Package
CXD1930AQ	DVD Player, MPEG	<ul style="list-style-type: none"> • MPEG2 (MP@ML) and MPEG1 video decoder • MPEG1, MPEG2 (layer I, II) and Dolby AC3 audio decoder (5+1 channels), linear PCM output • DVD, VCD, MPEG demultiplexing: up to 72Mbps • DVD standard compliant decoder • Letter box pan-scan output • On-screen display up to 256 colors • Sub-picture decoding 	208 Pin QFP

- MPEG Video Encoder

Part Number	Applications	Features	Package
CXD1922Q	Storage Media, Communications, Authoring, Consumer Products	<ul style="list-style-type: none"> • MPEG2 encoder, motion estimation and system rate controller on a single chip • Support MPEG2 MP@ML encoding compliant with ISO/IEC 13818-2 for frame structure encoding • High quality, real-time encoding (I, B, P) • Supports MP@ML, SP@ML with an image size of: <ul style="list-style-type: none"> — up to NTSC 720x480 @ 30fps — up to PAL 720x576 @ 25fps • MPEG2 Video Elementary Stream Output • Wide motion vector search range: <ul style="list-style-type: none"> — Horizontal: -288 to +287.5 — Vertical: -96 to +95.5 	208 Pin QFP

- NTSC/PAL Video Encoder

Part Number	Features	Input	Output	Package
CXD1915R ⁽¹⁾	Built-in 10-bit, 6 channel D/A converter, closed caption encode, VBID encode, WSS encode, Macrovision Pay-Per-View copy protection system, rev. 7.01	Y, Cb, Cr	Composite Video S-Video RGB/YUV	80 Pin LQFP
CXD1916R	Built-in 10-bit, 6 channel D/A converter, closed caption encode, VBID encode, WSS encode	Y, Cb, Cr	Composite Video S-Video RGB/YUV	80 Pin LQFP

NOTE:

1. The license contract for the Macrovision pay-per-view copy protection system is required.

Laser Diode

Red Laser Diode

Part Number	Applications	Features	Typ. Wavelength (nm)	Max. Optical Power Output (mW)	Package	Pins
SLD1131VS	Bar code reader	Small astigmatism, low current consumption	670	6	ø5.6mm	3
SLD1132VS	Laser pointer	Short wavelength	635	5		
SLD1133VL	Bar code reader	Index guided, small astigmatism	650	7		
SLD1135VS	Laser pointer	Index guided, small astigmatism	650	5		
SLD1137VS	Bar code reader	Index guided, small astigmatism, low power	650	7		

High Power Al GaAs Laser Diode

Part Number	Typ. Wavelength (nm)	Max. Optical Output (mW)	Package	Pins
SLD234VL	785	50	ø5.6mm, VL	3

Super High Power Laser Diode⁽¹⁾

Part Number	Typ. Wavelength (nm)	Max. Optical Power Output (mW)	Packages Available
SLD301	770 to 840	100	B, V, WT, XT
SLD304	770 to 840	1000	B, V, XT
SLD322	790 to 840	550	V, XT
SLD323	790 to 840	1100	V, XT
SLD324	790 to 840	2200	ZT
SLD326	795 to 840	4400	YT
SLD327 ⁽²⁾	795 to 840	3300	B, YT

NOTES:

1. Contact Sony for wavelength selection.
2. Under development.

LCD (Data Projector)

SVGA Data Projector LCD

Model	Display Size	Effec. Dots in Number	Optical Transmittance	Contrast Ratio
LCX031ALT	1.3"	486K dots (804H x 604V)	24% (Aperture Ratio: 67%)	350 : 1

Block Diagram

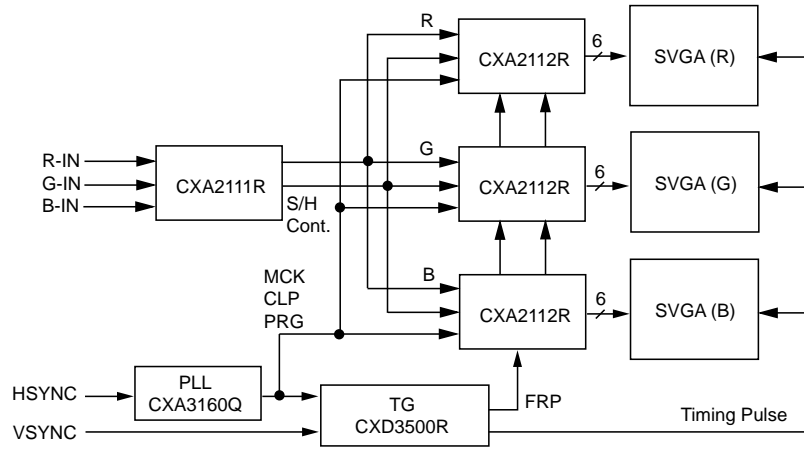

XGA Data Projector LCD

Model	Display Size	Effec. Dots in Number	Optical Transmittance	Aperture Ratio
LCX017CLT	1.8"	786K dots (1,024 x 768)	23%	69%
LCX023CMT	1.3"	768K dots (1,024 x 768)	30%	84% (Effective)
LCX029AMT	0.9"	786K dots (1,024 x 768)	21%	50% (Effective)

Block Diagram

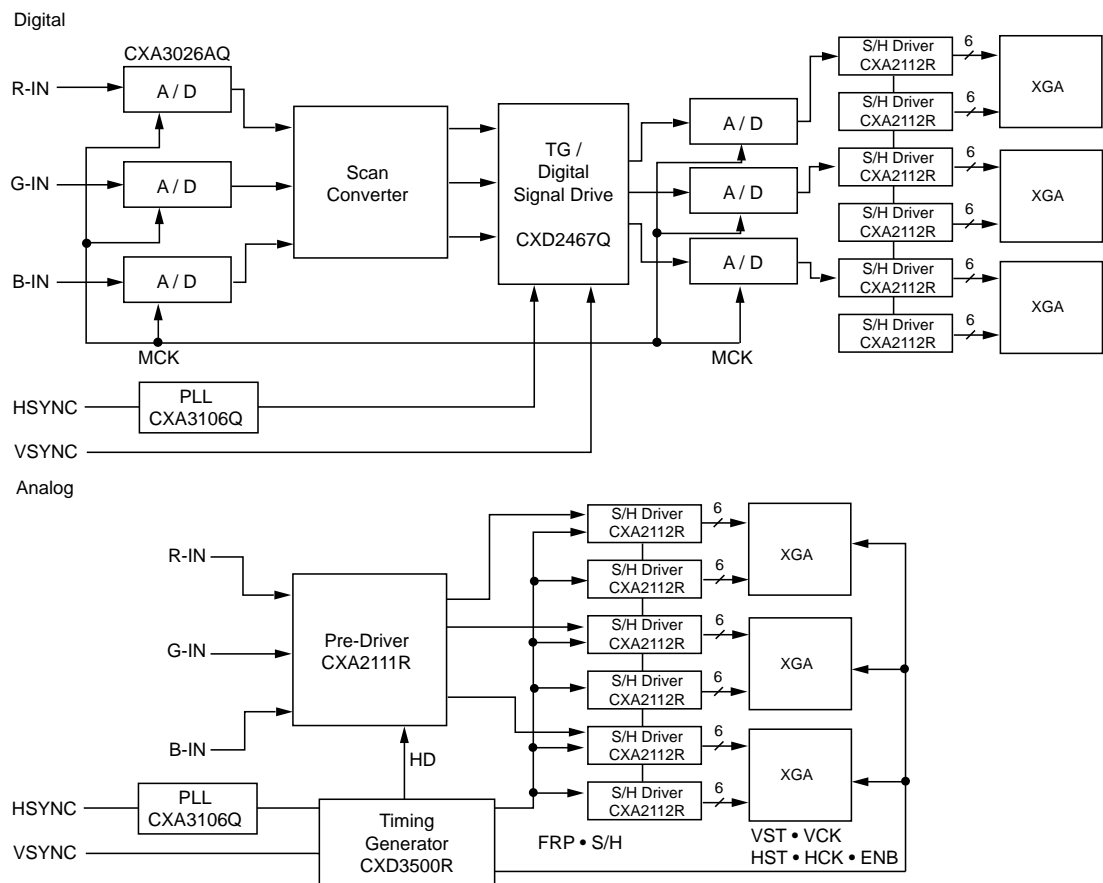

Mixed Signal Systems

Analog LCD I/F Chipset

A/D converters and PLLs are provided for LCD monitors and projectors according to the resolution.

In XGA resolution, the A/D converters CXA3246Q (QFP) and CXA3256R (LQFP), and the PLL CXA3106Q are available.

In SXGA resolution, the A/D converters CXA3276Q (QFP) and CXA3286R (LQFP), and the PLL CXA3106AQ are available.

The use of Sony's A/D converters and PLLs enables simple designing of XGA and SXGA with the same concept and gives excellent picture quality. Moreover, the D/A converter CXA3197R, which is capable of TLL interface, is provided for LCD projectors.

LCD Monitor System Block Diagram

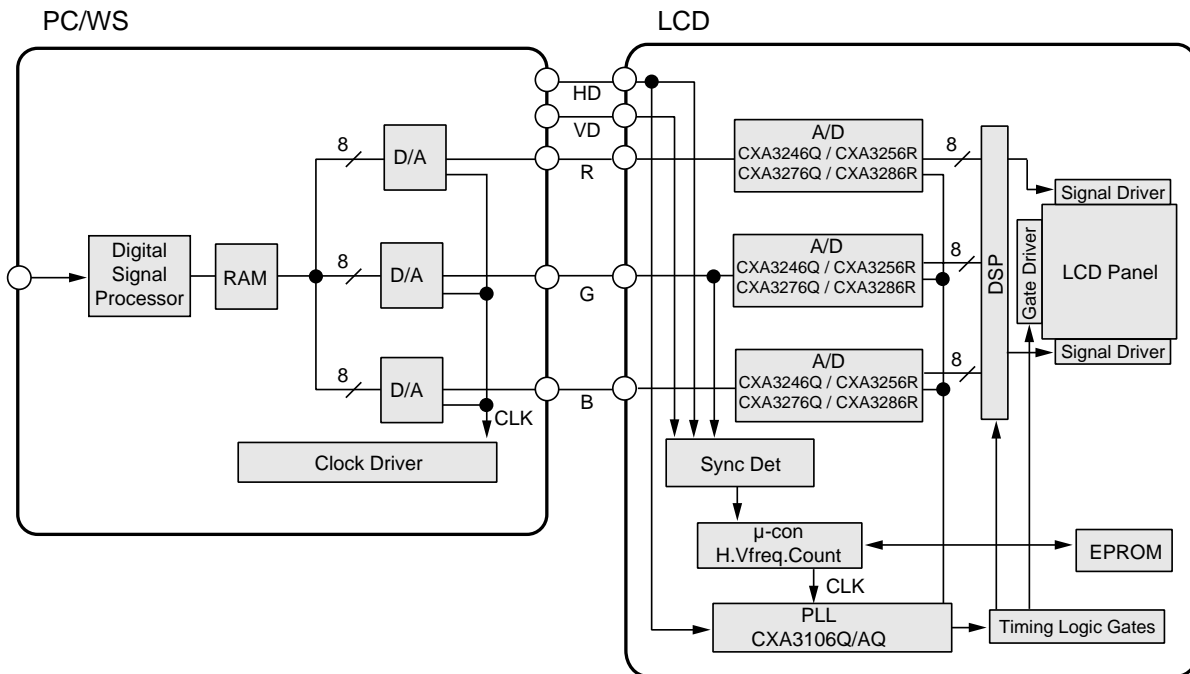

Function/Resolution	XGA	SXGA
A/D	CXA3246Q (8-bit 120M QFP)	CXA3276Q (8-bit 160M QFP)
	CXA3256R (8-bit 120M LQFP)	CXA3286R (8-bit 160M LQFP)
PLL	CXA3106Q	CXA3106AQ

Mixed Signal Systems (continued)

- A/D Converter Lineup

Product Name	Bits	Rate (MSPS)	Pd (mW)	Features	Supply Voltage (V)	Package	Pins
CXA3246Q	8	120	500	1 : 2 De-Multiplex TTL Output	4.75 to 5.25 or ±4.75 to ±5.25	QFP	48
CXA3256R	8	120	500	1 : 2 De-Multiplex TTL Output	4.75 to 5.25 or ±4.75 to ±5.25	LQFP	48
CXA3276Q	8	160	550	1 : 2 De-Multiplex TTL Output	4.75 to 5.25 or ±4.75 to ±5.25	QFP	48
CXA3286R	8	160	550	1 : 2 De-Multiplex TTL Output	4.75 to 5.25 or ±4.75 to ±5.25	LQFP	48

- D/A Converter Lineup

Product Name	Bits	Rate (MSPS)	PD (mW)	Features	Supply Voltage (V)	Package	Pins
CXA3197R	10	125	480	2 : 1 Multiplex TTL Input	4.75 to 5.25 or ±4.75 to ±5.25	LQFP	48

- PLL Lineup

Product Name	SyncInput (kHz)	Clock Output (MHz)	PD (mW)	Resolution	Supply Voltage (V)	Package	Pins
CXA3106Q	10 to 100	10 to 120	335	XGA or below	4.75 to 5.25	QFP	48
CXA3106AQ	10 to 100	10 to 160	350	SXGA or below			

- ADC (3ch) / AMP / PLL

Product Name	Bits	Rate	PD (W)	SyncInput (kHz)	Supply Voltage (V)	Package	Pins
CXA3506R	8	120	4	10 to 130	4.75 to 5.25	LQFP	144
CXA3516R	8	165	4	10 to 130	4.75 to 5.25	LQFP	144

Memory

Synchronous SRAM⁽¹⁾

Capacity	Part Number	Configuration	Features	Cycle Time (ns)	VCC (V)	Pins	Package
1Mb	CXK77B3610AGB	32K x 36 bits	Late Write, LVCMOS/LVTTL I/O, 4-Mode Operation ⁽²⁾	5, 6	3.3	119	BGA
	CXK77B1811AGB	64K x 18 bits	Late Write, LVCMOS/LVTTL I/O, 4-Mode Operation ⁽²⁾	5, 6	3.3	119	BGA
	CXK77B3611AGB	32K x 36 bits	Late Write, HSTL I/O, 4-Mode Operation ⁽²⁾	5, 6	3.3	119	BGA
	CXK77B1810AGB	64K x 18 bits	Late Write, HSTL I/O, 4-Mode Operation ⁽²⁾	5, 6	3.3	119	BGA
4Mb	CXK77B1840AGB ⁽⁴⁾	256K x 18 bits	Late Write, HSTL I/O, 4-Mode Operation ⁽²⁾	38, 4, 45	3.3	119	BGA
	CXK77B3641GB ⁽⁴⁾	128K x 36 bits	Late Write, LVCMOS/LVTTL I/O, 3-Mode Operation ⁽³⁾	6	3.3	119	BGA
	CXK77B1841GB ⁽⁴⁾	256K x 18 bits	Late Write, LVCMOS/LVTTL I/O, 3-Mode Operation ⁽³⁾	6	3.3	119	BGA
	CXK77B1841AGB ⁽⁴⁾	256K x 18 bits	Late Write, LVCMOS/LVTTL I/O, 3-Mode Operation ⁽³⁾	33, 37, 5, 6	3.3	119	BGA
	CXK77B3641AGB ⁽⁴⁾	128K x 36 bits	Late Write, LVCMOS/LVTTL I/O, 3-Mode Operation ⁽³⁾	33, 37, 5, 6	3.3	119	BGA

NOTES:

1. Delivery 16 weeks ARO. Check with marketing for available inventory.
2. Register-Register Mode, Register-Latch Mode, Register-FlowThru Mode, Dual Clock Mode.
3. Register-Register Mode, Register-Latch Mode, Register-Flow Thru Mode.
4. Contact marketing for production plan and schedule.

Serial/Optical Communications

• Transmitter ICs

Part Number	Function	Data Rate (typ.)	Power Consumption (mW) (typ.)	Supply Voltage (V)	Package ⁽²⁾	Pins
CXB1549Q	Laser Diode Driver (with built-in Op Amp)	1.25Gbps (min.)	195	3.3	QFP	40
CXB1818Q ⁽¹⁾	Laser Diode Driver with D-FF	622MHz	195	3.3	QFP	40

• Receiver ICs

Part Number	Function	Data Rate (typ.)	Power Consumption (mW) (typ.)	Supply Voltage (V)	Package ⁽²⁾	Pins
CXB1573R ⁽³⁾	Post Amp (2R IC)	531/622/ 1,062Mbps/ 1.25Gbps	165	3.3	LQFP	32
CXB1575AQ	Post Amp + CDR, built-in PLL (3R IC)	155Mbps	320	3.3	QFP	40
CXB1577Q ⁽³⁾	Post Amp (2R IC)	531/622/ 1,062Mbps/ 1.25Gbps	165, 250	3.3, 5.0	QFP	40
CXB1577R	Post Amp (2R IC)	551/622/ 1,062Mbps/ 1.25Gbps	250	5.0	LQFP	32
CXB1805Q	Post Amp + CDR (3R IC)	155/622Mbps	231	3.3	QFP	46
CXB1810FN	Post Amp (2R IC)	2.5Gbps	132, 400	3.3, 5	HSOP	16

• ATM/Gigabit Ethernet ICs/Fiber Channel ICs

Part Number	Function	Data Rate (typ.)	Power Consumption (mW) (typ.)	Supply Voltage (V)	Package ⁽²⁾	Pins
CXB1585N	Clock and Data Recovery (F.C. Repeater)	1,062Mbps	400	3.3	SSOP	24
CXB1590Q ⁽³⁾	ATM Transceiver w/PLL	622Mbps	825	3.3	QFP	80
CXB1595AN	Clock and Data Recovery (F.C. Repeater)	1,062Mbps	380	3.3	SSOP	30
CXB1596AR ⁽¹⁾	F.C. Transceiver with PLL (10mm x 10mm) Lower Power	1,062Mbps	650	3.3	LQFP	64

NOTES:

- Under development.
- QFP = Quad Plastic Flat Package
MQFP = Metal Quad Flat Package
CQFP = Ceramic Quad Flat Package
LQFP = Low Profile Quad Flat Package
SOP = Small Outline Package
- Requires minimum order of 10,000 pieces per year.

Serial/Optical Communications (continued)

- GVIF — Gigabit Video Interface

Part Number	Function	Including BLK	Resolution	Color Depth	Power Supply	PD (typ.)	Package (Body Size)
CXB1451Q	GVIF Transmitter	ENCODER P/S Converter PLL Synthesizer Cable Driver	VGA, SVGA & XGA	18-bit	+3.3V	0.8W	PQFP80 (14mm x 14mm)
CXB1452Q	GVIF Receiver	DECODER S/P Converter PLL Clock Recovery Cable Equalizer	VGA, SVGA & XGA	18-bit	+3.3V	1.0W	PQFP80 (14mm x 14mm)
CXB1454R	GVIF Receiver	TTL I/F DECODER Cable Equalizer PLL Synthesizer P/S Converter Common Mode Voltage Driver	VGA, SVGA, XGA	24-bit	+3.3V	1.1W	LQFP64 (14mm x 14mm)
CXB1455R	GVIF Transmitter	TTL /IF ENCODER P/S Converter PLL Synthesizer Cable Driver Common Mode Voltage Level Detector	VGA, SVGA, XGA	24-bit	+3.3V	0.25W	LQFP48 (7mm X 7mm)
CXB1456R	GVIF Receiver	TTL I/F DECODER Cable Equalizer PLL Synthesizer P/S Converter Common Mode Voltage Driver	VGA, SVGA, XGA	24-bit	+3.3V	0.25W	LQFP64 (10mm x 10mm)

GVIF Chip Set

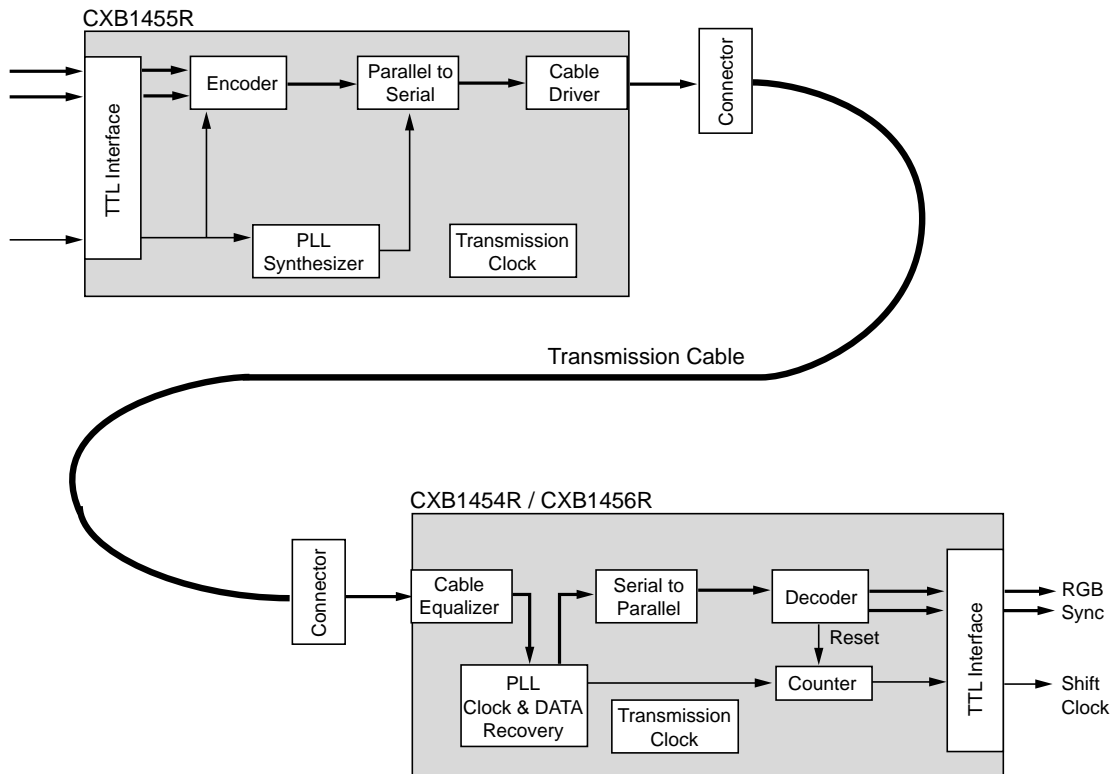

Serial/Optical Communications (continued)

• Applications

Application	Data Rate	Transmitter	LDD	T Amp.	2R IC	3R IC	Receiver	Repeater
SDH (SONET)	155Mbps	—	CXB1548QY CXB1558QY CXB1549Q CXB1818Q	CXA1685M	CXB1562AQ CXB1572Q	CXB1575AQ CXB1805Q	—	—
	622Mbps	—		CXA1684M	CXB1577Q	CXB1805Q	—	—
	2.5Gbps	—		—	CXB1810FN	—	—	—
FDDI	125Mbps	—		CXA1685M	CXB1562AQ CXB1572Q	—	—	—
Fibre Channel	133Mbps	—		CXA1685M	CXB1562AQ	—	—	—
	266Mbps	—		CXB1572Q	—	—	—	—
	531Mbps	—		CXA1684M	CXB1573R	—	—	—
	1.06Gbps	CXB1596AR		—	CXB1577R CXB1577Q	—	CXB1596AR	CXB1585N
ATM	622Mbps	CXB1590Q		CXA1684M	—	—	CXB1590Q	—
Gigabit Ethernet	1.25Gbps	CXB1596AR		—	CXB1573R CXB1577R CXB1577Q	—	CXB1596AR	—

• Transmission System

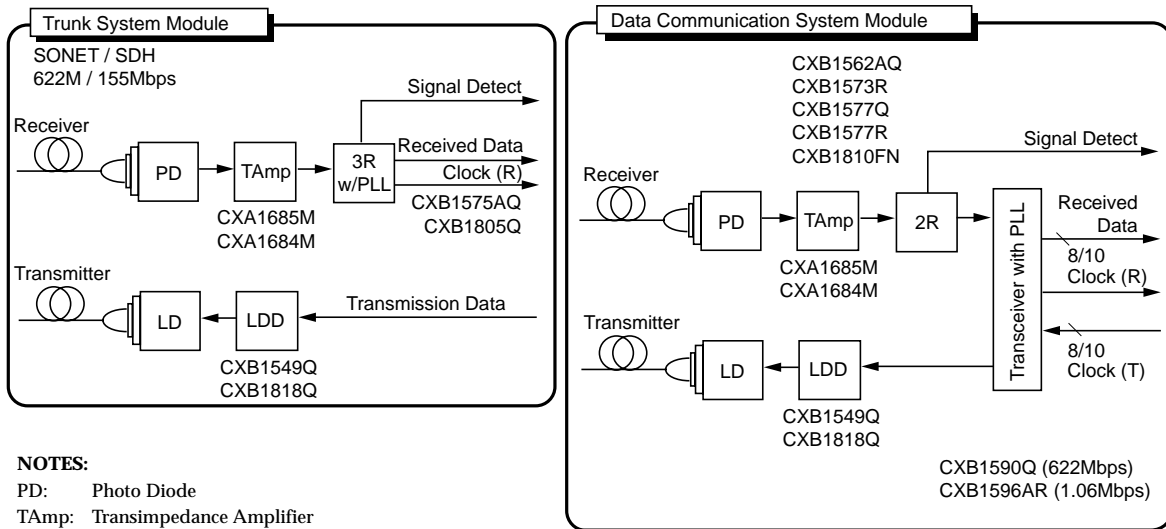

NOTES:

- PD: Photo Diode
- T Amp: Transimpedance Amplifier
- 2R: Reshaping & Regenerating
- 3R: Reshaping, Regenerating & Retiming
- LD: Laser Diode/LED
- LDD: Laser Diode Driver/LED Driver
- PLL: Phase-Locked Loop

TV

Part Number	Package	Function	Voltage
CXA2104S	SDIP	US TV Stereo & SAP Decoder, dbx-TV Noise Reduction Decoder, I ² C Bus	9
CXA2094Q	QFP		
CXA2054S	SDIP	US TV Stereo & SAP Decoder, dbx-TV Noise Reduction Decoder, I ² C Bus, Sound Processor, AGC	9
CXA2021S	SDIP	Sound Processor, I ² C Bus, Volume, Bass, Treble, Surround, AGC	12
CXA2022S		Sound Processor, I ² C Bus, Volume, Bass, Treble, 3-mode Surround, AGC	
CXD2043Q	QFP	NTSC, High Precision of Y/C Field Separation, Built-in 4fsc PLL	5
CXD2073Q		NTSC, 2 Line Comb, Built-in 4fsc PLL	
CXA2019AQ		Y/C Signal Processor	

— I²C Bus Controlled Audio/Video Switch

Part Number	Number of Inputs	Number of Outputs	Frequency Charac.	Features	Supply Voltage	Package	Pins
CXA2069Q	7	3	20MHz, -3dB	S2 Compatible, Audio/Video Switch	9	QFP	64
CXA2079Q	6	2					64
CXA2089Q	5	2					48

TV System Block Diagram

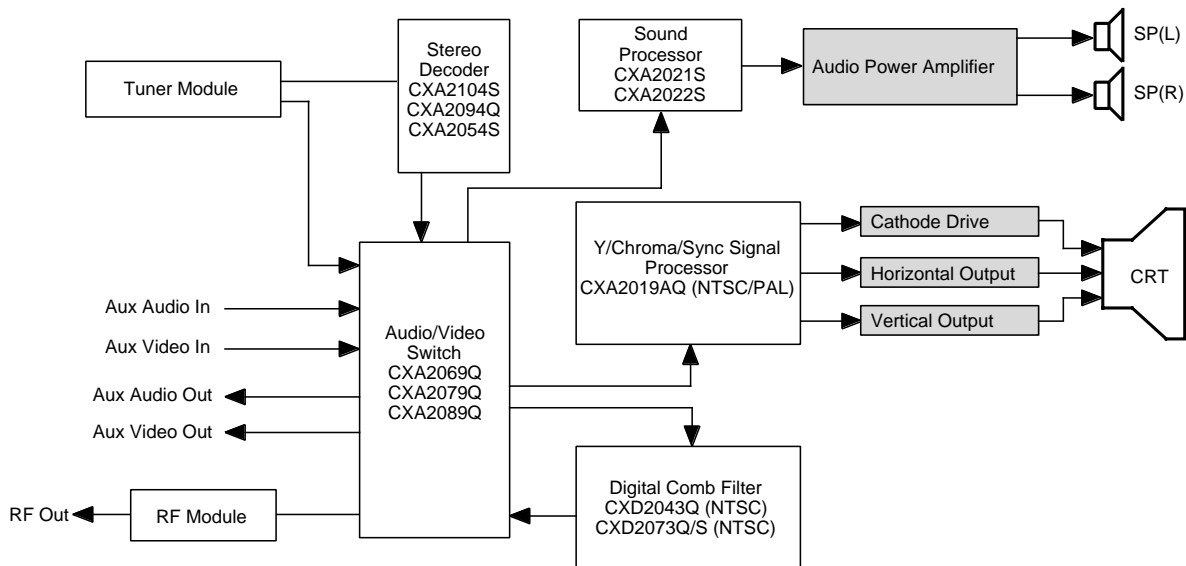

Wireless Communications

GaAs MMIC (Microwave Monolithic IC) — Switch IC

Part Number	Functions	Insertion Loss (dB)	Isolation (dB)	@ Frequency (GHz)	Control Voltage (V)	V _{DD} (V)	Package	C D M A	T D M A	G S M
CXG1077TN -T2, 1K/reel	SPDT	0.35 0.5	22 17	0.9 1.8	3 3	N/A	TSSOP-10	X	X	
CXG1028ATN -T2, 1K/reel	SPDT	0.3 0.5	22 17	0.9 1.9	3-5 ⁽¹⁾ 3-5 ⁽¹⁾	N/A	TSSOP-10	X	X	X
CXG1045N -T4, 1K/reel	DPDT	0.4 0.6	22 17	0.9 1.9	3-5 ⁽¹⁾ 3-5 ⁽¹⁾	N/A	SSOP-8	X	X	X
CXG1009TN -T2, 1K/reel	SPDT	0.7 0.8	56 44	1.0 2.0	3 3	N/A	TSSOP-10	X	X	X
CXG1022TM -T4, 1K/reel	SPDT	0.3	31	1.0	3	N/A	TSSOP-10	X	X	X
CXG1039TN -T2, 1K/reel	SPDT w/Logic	0.8	50	2.0	3	3	TSSOP-10	X	X	X
CXG1040TN -T2, 1K/reel	DPDT w/Logic	0.5	25	2.0	3	3	TSSOP-10	X		
CXG1025R -T4, 1K/reel	SP4T	1.0	45	2.4	3	3	LQFP-32	X	X	X
CXG1091TN -T2, 1K/reel	SP4T w/Logic	0.5 0.7	24 20	0.9 1.8	3 3	5 5	TSSOP-16		X	X
CXG1092N -T4, 1K/reel	SP5T w/Logic	0.5 0.7	24 20	0.9 1.8	3 3	5 5	SSOP-20		X	X

NOTES:

1. (Pin=35dBm, Vctl=5V) or (Pin=10dBm, Vctl=3V)

— Driver Amplifier

Part Number	Gain (dB)	P _{OUT} (dBm)	Distortion	Frequency (GHz)	Number of Stages	V _{DD} (V)	Package
CXG1027TM -T4, 1K/reel	29.5 27.5	10 10	ACPR=-65dBc ACPR=-65dBc	0.94 1.44	2 2	3.4	TSSOP-10

— Power Amplifier

Part Number	Gain (dB)	P _{OUT} (dBm)	Distortion	Frequency (GHz)	Number of Stages	V _{DD} (V)	Package
CXG1047FN -T2, 1K/reel	28	34	Harm (2f) <-42dBc (3f) <-37dBc	1.88	3	3.6	HSOF-16

— Low Noise Amp/Mixer

Part Number	Functions	NF (dB)	Gain (dB)	Frequency (GHz)	V _{DD} (V)	Package
CXG1013N -T4, 1K/reel	LNA Mixer	1.8 7.2	14.5 9	1.9 (flo=1.66) 1.9 (flo=1.66)	3.0 3.0	SSOP-16
CXG1034TN -T2, 1K/reel	Mixer	8.5	8	1.9 (flo=1.66)	3.0	TSSOP-10

Wireless Communications (continued)

CDMA Cellular/CDMA PCS IC — Gain Control Amplifier (AGC Amp)

	Part Number	Package	Input Port	fopr (MHz)	Vcc (V)	Gain Range (dB)	IIP3 (dBm)	NF (dB)
RF IF	CXA3001N -T4, 1K/reel	SSOP-24	Dual	10 to 100	3.1 to 3.8	-45 to +45	-38@G=40dB f=85.38MHz	6.5@G=40dB f=85.38MHz
	CXA3201AN -T4, 1K/reel	SSOP-16	Dual	50 to 300	2.7 to 3.8	-45 to +45	-38@G=40dB f=210.38MHz	5@G=40dB f=210.38MHz
	CXA3221AN -T4, 1K/reel	SSOP-8	Single	50 to 300	2.7 to 3.8	-45 to +45	-38@G=40dB f=210.38MHz	5@G=40dB f=210.38MHz
TX IF	CXA3002N -T4, 1K/reel	SSOP-24	Single	10 to 200	3.1 to 3.8	-40 to 40	-26@G=3.5dB f=130.38MHz	10@G=35dB f=130.38MHz
	CXA3202AN -T4, 1K/reel	SSOP-16	Single	50 to 300	2.7 to 3.8	-60 to 20	-5@G=15dB f=130.38MHz	25@G=15dB f=130.38MHz
	CXA3222AN -T4, 1K/reel	SSOP-8	Single	50 to 300	2.7 to 3.8	-60 to 20	-5@G=15dB f=130.38MHz	25@G=15dB f=130.38MHz

— Baseband Analog ASIC (BBASIC)

Part Number	Functions, Features	Supply Voltage (V)	Package	Pins
CXA3003BR ⁽¹⁾ -T6, 500/reel	Analog Baseband ASIC for CDMA, FM with I/Q DEM, I/Q MOD, PLL, A/D, D/A	3.3	LQFP	80
CXA3303R ⁽¹⁾ -T6, 500/reel		3.0	LQFP	80

NOTE:

1. Samples and data sheet to be distributed only to CDMA licensees.

Analog Cellular IC — IF Amplifier IC

Part Number	Functions, Features	Supply Voltage (V)	Package	Pins
CXA1741Q -T4, 1K/reel	FM IF amplifier with filter for TACS, NTACS	2.7 to 3.6	QFP	40
CXA1742Q -T4, 1K/reel	FM IF amplifier with filter for AMPS	2.7 to 3.6	QFP	40

— PLL IC

Part Number	Functions, Features	Supply Voltage (V)	Package	Pins
CXA1786N -T4, 1K/reel	1GHz-band single chip PLL for radio communication, power save mode	2.7 to 5.5	SSOP	20

Wireless Communications (continued)

GPS IC

Part Number	Functions, Features	Supply Voltage (V)	Package	Pins
CXA1951AQ -T4, 1K/reel	Receive down converter, LNA, mixer, IF amplifier, PLL, oscillator	2.7 to 5.5	QFP	40
CXD2930BR -TL, 500/reel	16-channel GPS signal processing IC, built-in 32-bit RISC CPU, 32Kbyte SRAM	3.0 to 3.6	LQFP	144
CXD2931R -TL, 500/reel	16-channel GPS signal processing IC, built-in 32-bit RISC CPU, 36Kbyte SRAM and 2Mbit MASK ROM	3.0 to 3.6	LQFP	144

GPS Receiver Module

Part Number	Functions	Supply Voltage (V)	Module Size	Weight
GXB1000	CXD2930BR + CXA1951AQ Module	3.0 to 3.6	47.3mm x 24.6mm	6.7g
GXB2000	CXD2931R + CXA1951AQ Module	3.0 to 3.6	36.5mm x 25.0mm	5.7g

Sony GPS System

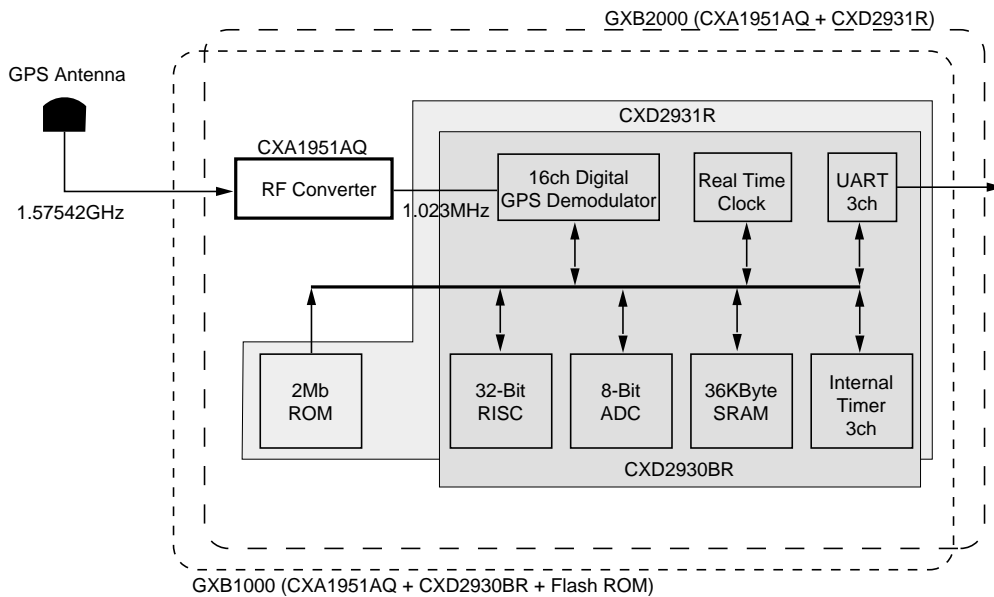

Wireless Communications (continued)

CDMA800/AMPS800 (Dual Mode)

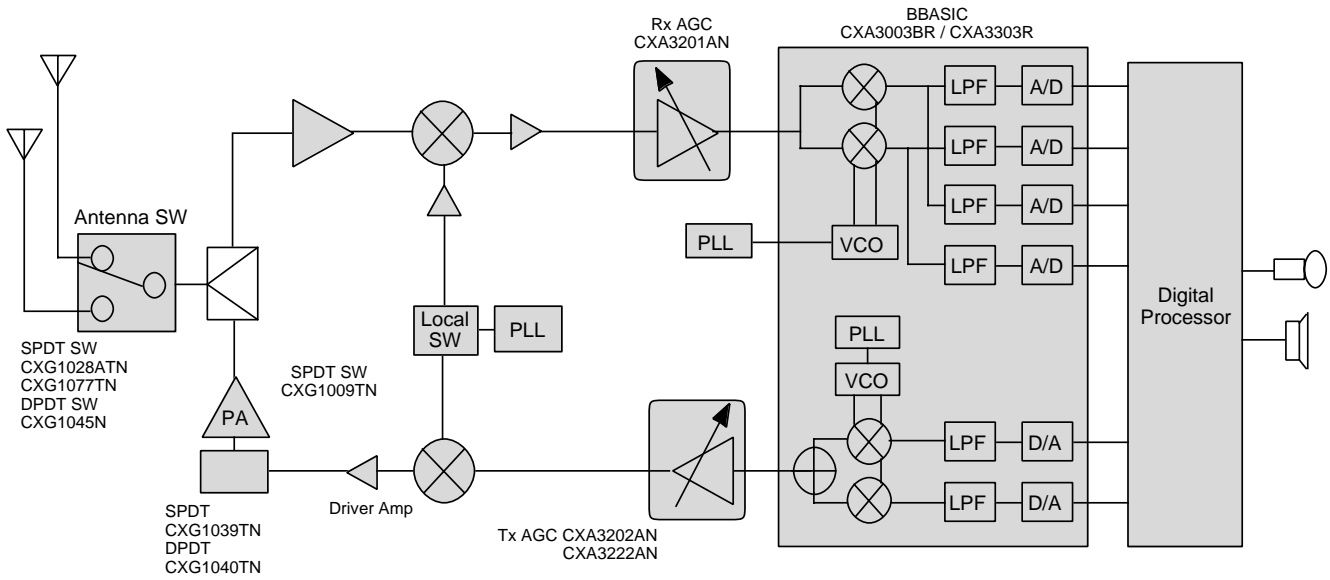

CDMA1900 (PCS)

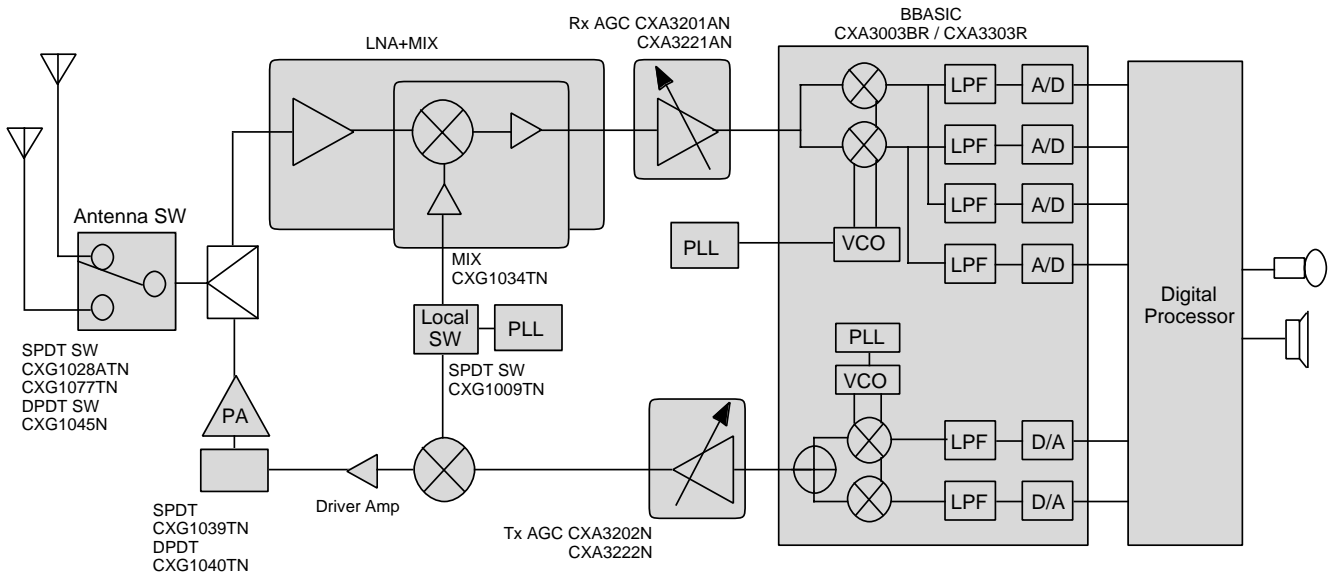

Wireless Communications (continued)

DCS1800/PCS1900 (GSM)

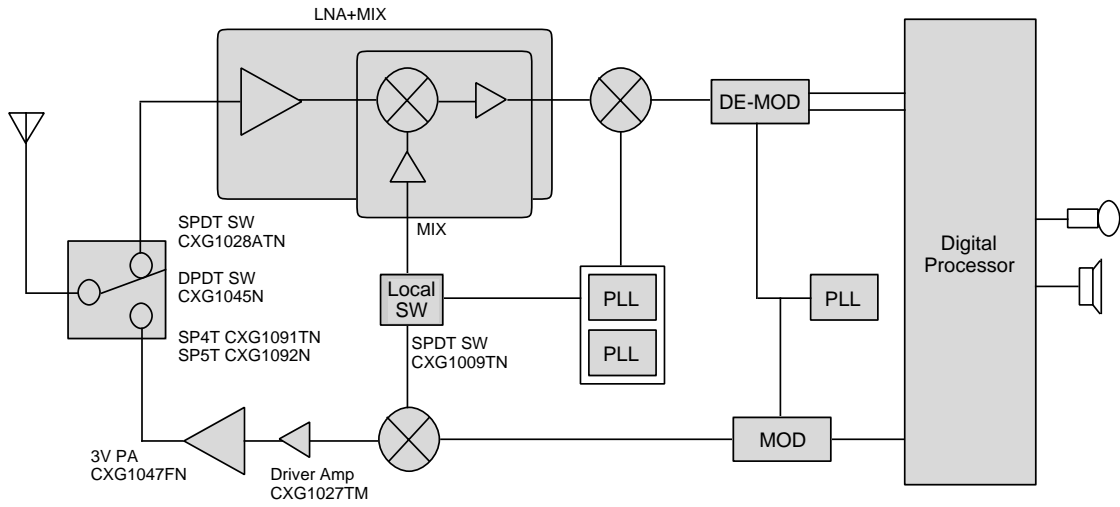

Pager System (Double Conversion)

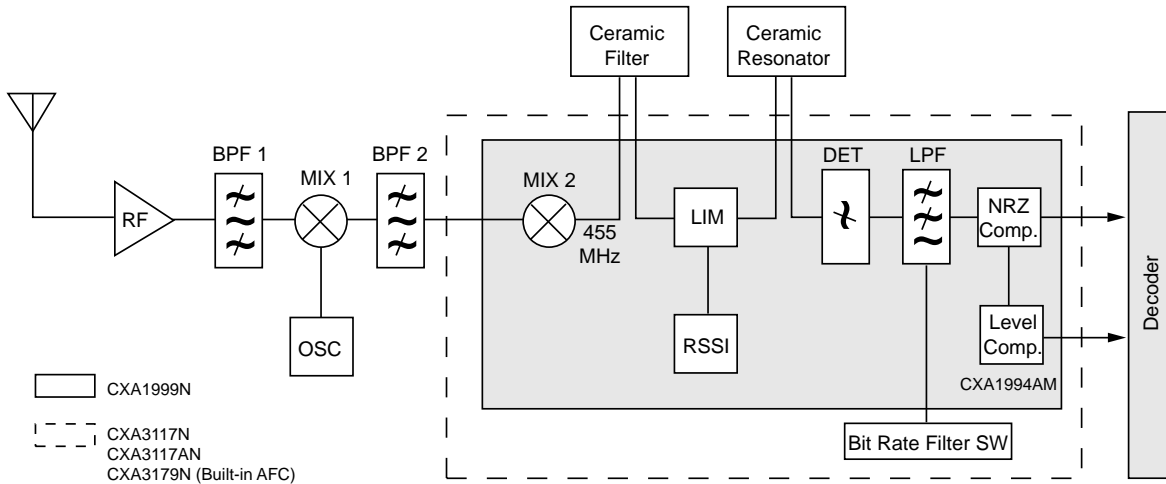

Wireless Communications (continued)

Pager IC

— FM IF Amplifier

Part Number	Structure	Functions, Features	Supply Voltage (V)	Package	Pins
CXA1999N -T4, 1K/reel	Double conversion	Low power FM IF amplifier with 4-level FSK comparator	1.1 to 4.0	SSOP	20
CXA3117N -T4, 1K/reel	Double conversion	Low power FM IF amplifier with 4-level FSK comparator, bit rate filter selection switch	1.1 to 4.0	SSOP	24
CXA3117AN -T4, 1K/reel	Double conversion	Low power FM IF amplifier with 4-level FSK comparator, bit rate filter selection switch. Quick charge by the detector output sense method	1.1 to 4.0	SSOP	24
CXA3176N -T4, 1K/reel	Double conversion	Super low power FM IF amplifier (w/second mixer), PACT compatible	1.1 to 4.0	SSOP	24
CXA3179N -T4, 1K/reel	Double conversion	Low power FM IF amplifier with 4-level FSK comparator, bit rate filter selection switch	1.1 to 4.0	SSOP	24

— Comparator

CXA1994AM -T4, 500/reel	—	4-level FSK comparator	1.0 to 4.0	SOP	8
----------------------------	---	------------------------	------------	-----	---

Index of Device Numbers

Product	Page	Product	Page	Product	Page	Product	Page	Product	Page
CXA1310AQ	.3	CXA3516R	.11	CXD2931R	.19	ICX059CL	.3	LCX023CMT	.9
CXA1390AR	.2	CXB1451Q	.14	CXG1009TN	.17	ICX074AK	.4	LCX029AMT	.9
CXA1391R	.2	CXB1452Q	.14	CXG1013N	.17	ICX074AL	.4	LCX031ALT	.9
CXA1592R	.2	CXB1454R	.14	CXG1022TM	.17	ICX075AK	.4	SLD1131VS	.8
CXA1690Q	.4	CXB1455R	.14	CXG1025R	.17	ICX075AL	.4	SLD1132VS	.8
CXA1741Q	.18	CXB1456R	.14	CXG1027TM	.17	ICX076AK	.2	SLD1133VL	.8
CXA1742Q	.18	CXB1549Q	.13	CXG1028ATN	.17	ICX076AL	.3	SLD1135VS	.8
CXA1786N	.18	CXB1573R	.13	CXG1034TN	.17	ICX077AK	.2	SLD1137VS	.8
CXA1951AQ	.19	CXB1575AQ	.13	CXG1039TN	.17	ICX077AL	.3	SLD234VL	.8
CXA1994AM	.22	CXB1577Q	.13	CXG1040TN	.17	ICX082AL	.3	SLD301	.8
CXA1999N	.22	CXB1577R	.13	CXG1045N	.17	ICX083AL	.3	SLD304	.8
CXA2006Q	.4	CXB1585N	.13	CXG1047FN	.17	ICX084AK	.4	SLD322	.8
CXA2019AQ	.16	CXB1590Q	.13	CXG1077TN	.17	ICX084AL	.4	SLD323	.8
CXA2021S	.16	CXB1595AN	.13	CXG1091TN	.17	ICX085AK	.4	SLD324	.8
CXA2022S	.16	CXB1596AR	.13	CXG1092N	.17	ICX085AL	.4	SLD326	.8
CXA2054S	.16	CXB1805Q	.13	CXK77B1810AGB	.12	ICX096AKE	.2	SLD327	.8
CXA2069Q	.16	CXB1810FN	.13	CXK77B1811AGB	.12	ICX097AKE	.2		
CXA2079Q	.16	CXB1818Q	.13	CXK77B1840AGB	.12	ICX098AK	.4		
CXA2089Q	.16	CXD1217M	.2	CXK77B1841AGB	.12	ICX204AK	.4		
CXA2094Q	.16	CXD1261AR	.3	CXK77B1841GB	.12	ICX204AL	.4		
CXA2104S	.16	CXD1265R	.2	CXK77B3610AGB	.12	ICX205AK	.4		
CXA3001N	.18	CXD1267AN	.2, 3, 4	CXK77B3641AGB	.12	ICX205AL	.4		
CXA3002N	.18	CXD1268M	.3, 4	CXL1517M	.2	ICX206AK	.2		
CXA3003BR	.18	CXD1915R	.7	CXL1518M	.2	ICX206AL	.3		
CXA3106AQ	.10, 11	CXD1916R	.7	CXL5504M	.2	ICX206AKB	.2		
CXA3106Q	.10, 11	CXD1922Q	.7	GXB1000	.19	ICX207AK	.2		
CXA3117AN	.22	CXD1930AQ	.7	CXB2000	.19	ICX207AL	.3		
CXA3117N	.22	CXD2043Q	.16	ICX038DLA	.3	ICX207AKB	.2		
CXA3176N	.22	CXD2073Q	.16	ICX038DNA	.2	ICX208AK	.2		
CXA3179N	.22	CXD2311AR	.4	ICX038DNB	.2	ICX208AKB	.2		
CXA3197R	.10, 11	CXD2401R	.2	ICX039DLA	.3	ICX208AL	.3		
CXA3201AN	.18	CXD2408AR	.4	ICX039DNA	.2	ICX209AK	.2		
CXA3202AN	.18	CXD2409R	.3	ICX039DNB	.2	ICX209AL	.3		
CXA3221AN	.18	CXD2424R	.4	ICX054BK	.2	ICX209AKB	.2		
CXA3222AN	.18	CXD2434ATQ	.4	ICX054BL	.3	ILX548K	.4		
CXA3246Q	.10, 11	CXD2437TQ	.4	ICX055BK	.2	ILX550K	.4		
CXA3256R	.10, 11	CXD2450R	.4	ICX055BL	.3	ILX551A	.4		
CXA3276Q	.10, 11	CXD2457R	.4	ICX058CK	.2	ILX553A	.4		
CXA3286R	.10, 11	CXD2460R	.4	ICX058CL	.3	ILX554A	.4		
CXA3303R	.18	CXD2463R	.3	ICX059CK	.2	ILX751A	.4		
CXA3506R	.11	CXD2930BR	.19			LCX017CLT	.9		

Sony Electronics Inc.
Semiconductor Business Division
Authorized Sales Representatives

Alabama: Rep, Inc. — 256/881-9270

Alaska: Sony — 408/955-6570

Arkansas: Component Technology — 918/254-4787

Arizona: Reptronix — 602/230-2630

California:

(North) Phase II Technical Sales — 408/980-0414 or
916/663-3558

(South) DynaRep, Inc. — 805/777-1185 or 714/573-1223

(San Diego) AdDEM — 858/794-1999

Colorado: Wescom Marketing — 303/432-6809

Connecticut: S-J Associates — 203/723-4707

Delaware: S-J Associates — 856/866-1234

District of Columbia: S-J Associates — 703/533-2233

Florida: Conley & Assoc. — 407/365-3283 or 727/572-8895

Georgia: Rep, Inc. — 770/938-4358

Hawaii: Sony — 408/955-6570

Idaho:

(North) Phase II Technical Sales — 503/292-7922

(South) Wescom Marketing — 208/377-5585

Illinois:

(North) Janus, Inc. — 630/250-9650

(South) Lorenz Sales — 913/469-1312

Indiana: Skyline Sales & Assoc. — 219/489-4992

Iowa: Lorenz Sales — 319/294-1000

Kansas: Lorenz Sales — 913/469-1312

Kentucky: Skyline Sales & Assoc. — 317/587-1320

Louisiana: Component Technology — 972/783-8831

Maine: S-J Associates — 978/670-8899

Maryland: S-J Associates — 703/533-2233

Massachusetts: S-J Associates — 978/670-8899

Michigan: Skyline Sales & Assoc. — 734/416-1493

Minnesota: Vector Design Technology — 651/631-1334

Mississippi: Rep, Inc. — 256/881-9270

Missouri: Lorenz Sales — 314/997-4558

Montana: Phase II Technical Sales — 425/821-8313

Nebraska: Lorenz Sales — 402/932-3314

Nevada:

(North) Phase II Technical Sales — 916/663-3558

(Clark County) Reptronix — 602/230-2630

New Hampshire: S-J Associates — 978/670-8899

New Jersey:

(North) S-J Associates — 516/536-4242

(South) S-J Mid-Atlantic — 856/866-1234

New Mexico: Reptronix — 505/292-1718

New York:

(Metropolitan) S-J Associates — 516/536-4242

(Upstate) L-MAR — 607/785-1185 or 716/425-9100

North Carolina: Rep, Inc. — 919/469-9997 or 704/527-7200

North Dakota: Vector Design Technology — 651/631-1334

Ohio: Skyline Sales & Assoc. — 440/846-0019

Oklahoma: Component Technology — 918/254-4787

Oregon: Phase II Technical Sales — 503/292-7922

Pennsylvania:

(West) Sony — 781-246-5868

(East) S-J Associates — 856/866-1234

Rhode Island: S-J Associates — 978/670-8899

South Carolina: Rep, Inc. — 919/469-9997 or 704/334-9289

South Dakota: Vector Design Technology — 651/631-1334

Texas:

(Austin) Component Technology — 512/246-8512

(Dallas) Component Technology — 972/783-8831

(El Paso County) Reptronix — 505/292-1718

(Houston) Component Technology — 281/599-8573 or
281/655-0550

Tennessee: Rep, Inc. — 770/938-4358

Utah: Wescom Marketing — 801/269-0419

Vermont: S-J Associates — 978/670-8899

Virginia: S-J Associates — 703/533-2233

Washington: Phase II Technical Sales — 425/821-8313

West Virginia: S-J Associates — 703/533-2233

Wisconsin:

(West) Vector Design Technology — 651/631-1334

(East) Janus, Inc. — 414/646-5420

Wyoming: Wescom Marketing — 208/377-5585

Canada:

Alberta: Davetek Marketing Inc. — 403/283-3577

British Columbia: Davetek Marketing Inc. — 604/430-3680

Montreal: Kaltron — 905/264-3968

Ontario: Kaltron — 613/256-5278

Quebec: Kaltron — 514/630-7238

Puerto Rico:

Rio Piedras: Economic Marketing Services — 787/287-2665

Sony Electronics Inc.
Semiconductor Business Division
Authorized Distributors

Alabama:		Minnesota:	
Avnet	256/837-8700	Avnet	612/346-3000
Arizona:		Bell Microproducts	612/943-1122
Avnet	516/434-7439	Missouri:	
	520/742-0515	Avnet	314/291-5350
	602/736-7000	North Carolina:	
Bell Microproducts	602/267-9551	Avnet	919/859-9159
California:		New Jersey:	
Avnet	408/435-3500 or 408/942-4600	Avnet	609/222-6400
			973/515-1640
	619/571-7540	Bell Microproducts	973/244-9668
	818/594-8370	New Mexico:	
	916/632-4500	Avnet	505/293-5119
	949/789-4100	New York:	
Bell Microproducts	408/451-9400	Avnet	315/449-4927
	619/597-3010		516/434-7400
	818/865-0266		716/475-9130
	949/470-2900	Bell Microproducts	516/543-2000
Colorado:		Ohio:	
Avnet	303/790/1662	Avnet	440/497-7600
Bell Microproducts	303/846-3065		614/888-3313
Connecticut:		Oklahoma:	
Avnet	203/271-5700	Avnet	918/459-6000
Florida:		Oregon:	
Avnet	407/657-3300	Avnet	503/526-6200
	727/507-5000	Bell Microproducts	503/524-0787
	954/677-3500	Texas:	
Bell Microproducts	407/682-1199	Avnet	214/553-4300
Georgia:			512/219-3700
Avnet	770/623-4400		713/781-6100
Iowa:		Bell Microproducts	512/258-0725
Avnet	319/393-0033		972-783-4191
Illinois:		Utah:	
Avnet	847/797-7300	Avnet	801/365-3800
Bell Microproducts	847/413-8530	Bell Microproducts	801/295-3900
Indiana:		Washington:	
Avnet	317/573-3500	Avnet	425/882-7000
Kansas:		Wisconsin:	
Avnet	913/663-7900	Avnet	262/513-1500
Maryland:		Canada:	
Avnet	410/720-3400	Avnet	514/335-1000
Bell Microproducts	410/720-5100		604/420-4101
Massachusetts:			905/812-4400
Avnet	978/532-9808	Puerto Rico:	
Bell Microproducts	781/933-9010	Avnet —	787/765-6207
Michigan:			
Avnet	734/416-5800		

**Sony Electronics Inc.
Component Company
Semiconductor Business Division
3300 Zanker Road, San Jose, CA 95134
Tel: (408) 955-6572 Fax: (408) 955-5176
www.sony.com/semi**

The Sony of Semiconductors.

© 2000 Sony Electronics Inc. Product specifications subject to change without notice. The purchase of products is subject to availability and Sony's standard terms and conditions of sale. Sony is a trademark of Sony.